

Dismantling the Pump



Pumps which convey hazardous liquids must be decontaminated before dismantling the pump. The appropriate personal protection equipment should be used.

Tools required: Torque wrench with socket - across flats 28mm (M16 locknut), 34mm (M24 locknut), 46mm (M36 locknut), Engineers pliers, Hide mallet, Open ended spanner - across flats 19mm, Special centering clips, Allen key - 8mm & 10mm across flats, Impeller holding tool, 3mm hexagonal bit



- 1) Isolate the motor (1) from the power supply.
- 2) Disconnect the inlet, outlet and flush connections. Remove the shaft guard (15). Remove the flush connectors (23).



Risk of contact with liquid being pumped.

ATTENTION

- 3) Refit the seal cartridge centering clips (these were supplied with the instruction manual). Turn the shaft (14) so that they can be refitted on centres (see diagram).

- 4) Unscrew the clamp ring handle (8) by several turns and lift the clamp ring (7) over the flanged adaptor (5).
- 5) Remove the cover (18).
- 6) Unscrew the impeller locknut (22) using the torque wrench and impeller holding tool (right hand thread).
- 7) Slide the impeller vane plate (20) and (where fitted) the back plate (19) forward off the shaft (14) by maintaining an even pressure. Hitting the impeller can cause serious damage.
- 8) Where required, remove the key (21) from the pump stub shaft (14).
- 9) Loosen the cartridge drive collar grub screws, ensuring that they are clear of the cartridge bore.

- 10) Remove the housing plate screws (6) and gently pull the housing plate and cartridge assembly out of the flanged adaptor.
- 11) Remove the cartridge screws (44) to release the cartridge from the housing plate. The cartridge can be inspected.
- 12) Remove the flanged adaptor (5).

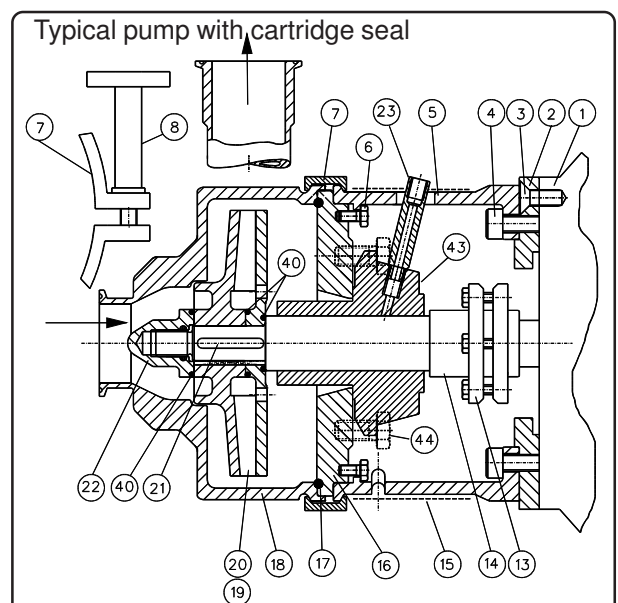

Burgmann Cartex SDN20 - view from motor end

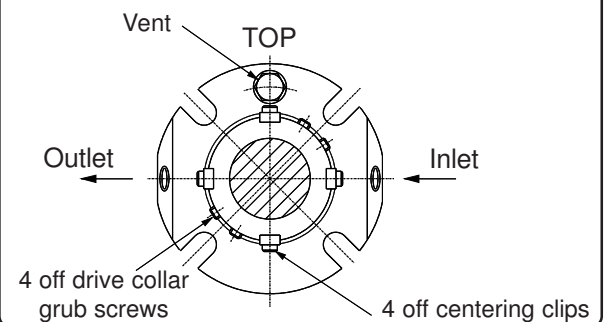

Reassembling the Pump

- 1) Replace the flanged adaptor (5).
- 2) Fit the cartridge seal (43) (see page S2).
- 3) Refit the key (21) into the pump stub shaft (14) and refit the impeller joint ring (40).
- 4) Slide the impeller back plate (19) (where fitted) and the vane plate (20) onto the pump stub shaft.
- 5) Screw on the impeller locknut (22) (right hand thread) and tighten to the specified torque (see table) using the impeller holding tool.
- 6) Refit the cover (18).
- 7) Fit the clamp ring (7) into position and tighten the clamp ring handle (8), ensuring that the clamp ring is correctly located.
- 8) Refit the flush connectors (23), then connect the inlet, outlet and flush connections. Ensure that the flush flow direction is correct (see diagram).

Pump model	Locknut torque (Nm)
H & CH	90 (M16 locknut)
	140 (M24 locknut)
	180 (M36 locknut)

- 9) Refit the shaft guard (15).
- 10) Check that the flush is operating and that the seal chamber is filled with fluid and is fully vented.

ATTENTION

This check should be done after seal installation and after any period of pump shut down. Dry running will cause overheating and may damage the mating surfaces.

Replacing the Cartridge seal - type Burgmann Cartex SDN20

ATTENTION

Mechanical seals are precision products. Installation should be carried out to the laid down procedure. Seals should be installed in a clean environment with particular care given to the lapped and polished seal faces.

Note: - For information on the seal fitted in your pump, please refer to the data sheet.

Tools required: Diluted soft soap solution, Allen key - 10mm across flats, Torque wrench 0-20Nm, Socket - across flats 17mm, Open ended spanner - across flats 17mm, Special centering clips, 3mm hexagonal bit, Loctite 243, Grub screws (4 off) M6x12mm H45 ISO 4029.

Removing the old seal: Dismantle the pump and seal as described on page S1.

Fitting the new seal:

- 1) Ensure all components are clean. Any sharp edges on the shaft shoulder or keyway should be removed.
- 2) If the cartridge is new, carefully remove the protective coating. Do NOT remove the centering clips (4) yet.
- 3) Ensure that the cartridge grub screws (5) are clear of the cartridge bore, and check that the 'O' rings (9 & 10) are undamaged and in position.
- 4) Fit the cartridge (3) onto the housing plate (1) with the cartridge screws (2) - DO NOT TIGHTEN at this stage.
- 5) Lubricate the shaft (6) with a very slight smear of diluted soft soap solution. **Never use mineral oil, grease, vaseline, etc, as it is not hygienic.**
- 6) Slide the cartridge and housing plate assembly (3,1) onto the shaft (6), locating the housing plate into the flanged adaptor (7).
- 7) Ensure that the vent is at the top and that the 4 off centering clips (4) are positioned on centres (see diagram).
- 8) Screw the housing plate screws (8) into the housing plate (1) and tighten to 14 Nm.
- 9) Fully tighten the cartridge screws (2) with an even pressure by tightening in an alternating pattern ¼ turns, 180° apart - do not overstress or distort the gland plate.
- 10) Ensure that the inlet and outlet connections are positioned as shown in the relevant diagram.
- 11) Degrease the grub screws and secure with 1 drop each of liquid screw retainer (eg loctite 243).
- 12) Lightly and evenly tighten the drive collar grub screws (5) to centralise the cartridge on the shaft. Then fully and evenly tighten the grub screws crosswise to the shaft to a torque of 7Nm.

ATTENTION

The grub screws must be used only once. Repeated use reduces force transmission.

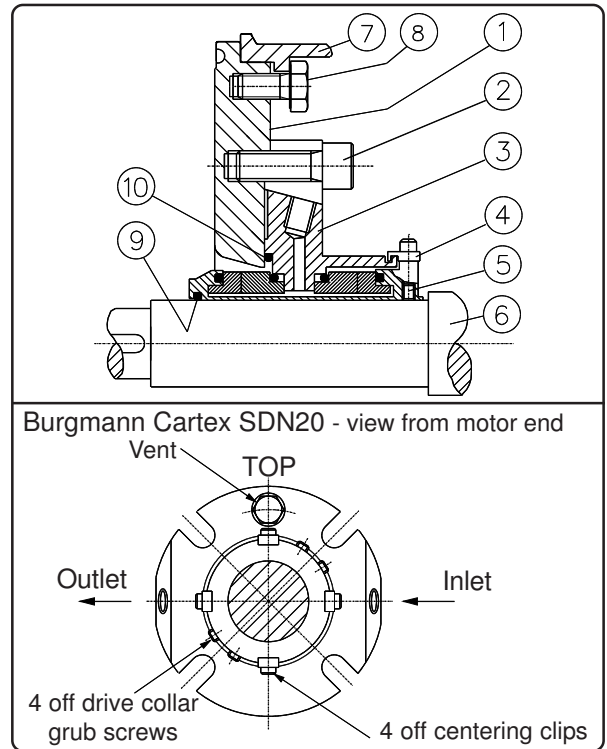

ATTENTION

Accurate tightening will avoid damage to the grub screws and eliminate seal movement on the shaft.

- 13) Remove and keep the centering clips (4) for future use.



Centering clips must be removed before rotating the shaft by hand or starting the pump.

- 14) Turn the shaft (6) by hand to ensure free rotation.

- 15) Reassemble the pump as described on page S1.

- 16) Before start-up, check that the flush is operating and that the seal chamber is filled with fluid and is fully vented.

ATTENTION

This check should be done after seal installation and after any period of pump shut down. Dry running will cause overheating and may damage the mating surfaces.