

## Dismantling the Pump



Pumps which convey hazardous liquids must be decontaminated before dismantling the pump. The appropriate personal protection equipment should be used.

*Tools required: Torque wrench with socket - across flats 28mm (M16 locknut), 34mm (M24 locknut), 46mm (M36 locknut), Engineers pliers, Hide mallet.*



1) Isolate the motor (1) from the power supply.

2) Disconnect the inlet and outlet connections.



Risk of contact with liquid being pumped.

3) Unscrew the clamp ring handle(s) (8) by several turns and lift the clamp ring (7) over the flanged adaptor (5).

4) Remove the cover (18).

5) Unscrew the impeller locknut (22) with the spanner (right hand thread).

6) Slide the impeller vane plate (20) and (where fitted) the back plate (19) forward off the shaft (14) by maintaining an even pressure. Hitting the impeller can cause serious damage.

7) Remove the key (21) from the pump stub shaft (14).

8) The mechanical seal (9) is now accessible. Clean the shaft and slide the seal forwards off the shaft.

9) The face of the seal is now exposed and can be inspected.

10) To remove the seal seat assembly (10,11), unscrew the housing plate screws (where fitted) and take out the housing plate (16). The seal seat (11) and seat ring (10) can both be inspected.

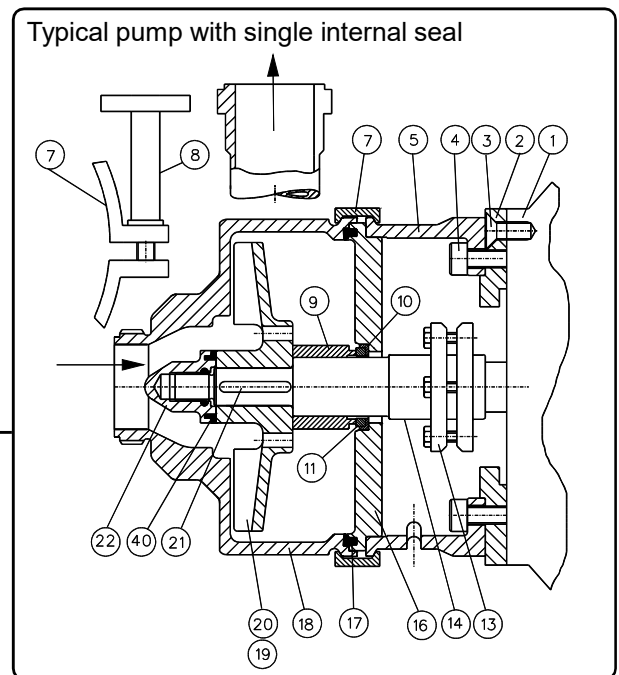

## Reassembling the Pump

1) Fit the mechanical seal (9) (see page S2).

2) Refit the key (21) into the pump stub shaft (14).

3) Slide the impeller back plate (19) (where fitted) and the impeller vane plate (20) onto the pump stub shaft (14).

4) Screw on the impeller locknut (22) (right hand thread) and finally tighten to the specified torque (see table).

5) Refit the cover (18).

6) Fit the clamp ring (7) into position and tighten the clamp ring handle(s) (8), ensuring that the clamp ring is correctly located.

Pump model	Locknut torque (Nm)
H & CH	90 (M16 locknut)
	140 (M24 locknut)
	180 (M36 locknut)

7) Connect the inlet and outlet connections.

8) Before start-up, the pump should be flooded with liquid at the seal faces as dry running will cause overheating and may damage the mating surfaces.

## Replacing the Seal - type 59U or 680

**ATTENTION**

Mechanical seals are precision products. Installation should be carried out to the laid down procedure. Seals should be installed in a clean environment with particular care given to the lapped and polished seal faces.

Notes: - For information on the seal fitted in your pump, please refer to the data sheet.

- The diagrams show seals with 'BP' type seats, although different seats are available.

*Tools required: Diluted soft soap solution, Seal fitting tube & sleeve (recommended), Torque wrench 1-20 Nm & hex drive bit - see table below.*

### Removing the old seal:

Dismantle the pump and seal as described on page S1.

### Fitting the new seal†:

- 1) Remove any grub screw burrs from the pump stub shaft.
- 2) Ensure all components are clean. Any sharp edges on the shaft shoulder or keyway should be removed.
- 3) Type 59U only: remove the 4 off retention clips before fitting the new seal onto the shaft.
- 4) Fit the seat (2) into the seat ring (3) to form the seat assembly.
- 5) Press the seat assembly\* fully down into the recess in the housing plate (1). Ensure that it is at right angles to the axis of the shaft and that the lapped sealing surface will face **towards** the mechanical seal assembly.
- 6) Fit the housing plate (1) into the flanged adaptor and tighten the housing plate screws (where applicable). Take care during assembly that the seal seat does not contact the shaft and become chipped. Ensure that the shaft guard (where supplied) is in position.
- 7) Lubricate the shaft with a very slight smear of diluted soft soap solution. **Never use mineral oil, grease, vaseline, etc, as it is not hygienic.**
- 8) Ensure that the grub screws (4) are well clear of the bore of the retainer (5).
- 9) Slide the seal unit gently onto the shaft, taking particular care when passing the seal over the stepped shaft not to damage the bore of the seal face. If the type 59U seal does not slide easily, remove it from the shaft, reverse it and push it gently onto the shaft so as to ease the wedge. Then remove the seal, place it on the shaft the right way round and slide it onto the shaft.
- 10) Fit the impeller and backplate (where applicable) onto the shaft and tighten the locknut. This will ensure that the seal is at the correct working length.
- 11) Lightly tighten the grub screws (4) in the retainer (5), centralising the seal on the shaft.
- 12) Unscrew the locknut and remove the impeller and backplate (where applicable) from the shaft. Tighten the grub screws† (4) to the specified torque (see table below).
- 13) Reassemble the pump as described on page S1.
- 14) Before start-up, the pump should be flooded with liquid at the seal faces as dry running will cause overheating and may damage the mating surfaces.

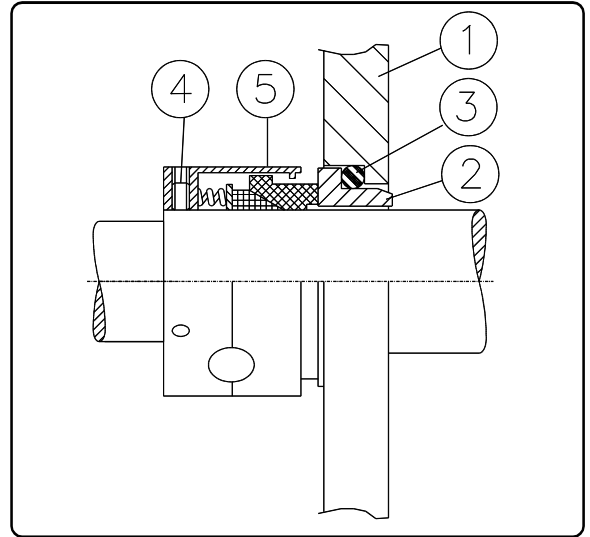

Grub screw		
Size	Hex bit size	Torque
M5	2.5 mm	3 Nm
M6	3.0 mm	4 Nm
M8	4.0 mm	11 Nm

† **Mechanical seal grub screws** - once tightened the screws should not be reused. If the screws are loosened for any reason, they must be replaced.

### \*Pegged seats:

When pegged seats are fitted, ensure that the hole or notch in the seat (6) is lined up with the peg (7) which protrudes from the seal seat housing. Failure to do so will result in seal failure.

