

Dismantling the Pump



Pumps which convey hazardous liquids must be decontaminated before dismantling the pump. The appropriate personal protection equipment should be used.

Tools required: Open ended spanner - across flats 1 1/8" (D3, D4, D4V), 46 mm (D5, D5V, D6, D6V) Engineers pliers, Screwdriver - medium flat blade, Hide mallet, Allen key - 6 mm across flats. (Where supplied - torque wrench, 1 1/8" or 46 mm deep series socket, special impeller tool).



1) Isolate the motor (1) from the power supply.

2) Disconnect the inlet and outlet connections.



Risk of contact with liquid being pumped.

3) Unscrew the clamp ring handle(s) (8) by several turns and lift the clamp ring (7) over the flanged adaptor (5).

4) Remove the cover (18).

5) Unscrew the impeller locknut (22) with the spanner (right hand thread).

6) Slide the impeller vane plate (20) and (where fitted) the back plate (19) forward off the shaft (14) by maintaining an even pressure. Hitting the impeller can cause serious damage.

7) Remove the key (21) from the pump stub shaft (14).

8) The mechanical seal (9) is now accessible. Clean the shaft and slide the seal forwards off the shaft.

9) The face of the seal is now exposed and can be inspected.

10) To remove the seal seat assembly (10,11), unscrew the housing plate screws (6) and take out the housing plate (16). The seal seat (11) and seat ring (10) can both be inspected.

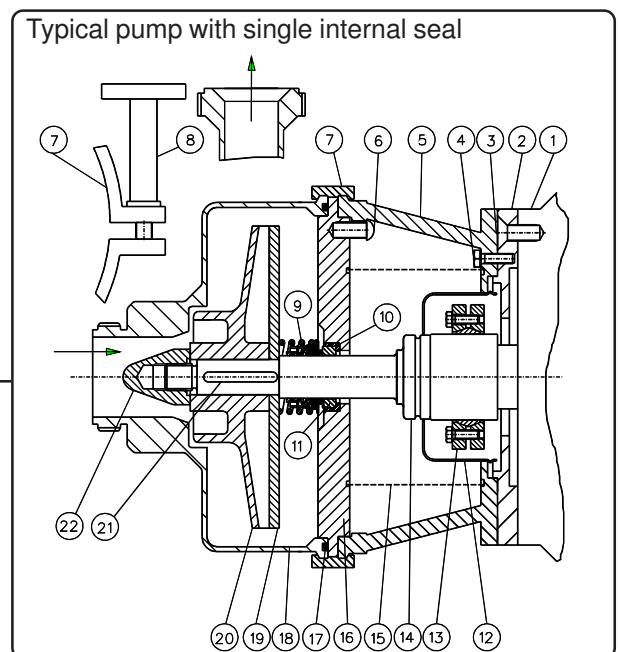

Reassembling the Pump

1) Locate the seal seat assembly (10,11) in the housing plate (16), fit the housing plate into the flanged adaptor (5) and tighten the housing plate screws (6). Take care during assembly that the seal seat (11) does not contact the shaft (14) and become chipped. Ensure that the shaft guard (15) is in position.

2) Fit the mechanical seal (9) (see page S2).

3) Replace the key (21) in the pump stub shaft (14).

4) Slide the impeller back plate (19) (where fitted) and the impeller vane plate (20) onto the pump stub shaft (14).

5) Screw on the impeller locknut (22) (right hand thread) and tighten with the spanner. If supplied, hold the impeller with the special tool and tighten with the torque wrench to 90 Nm (D3, D4) or 180 Nm (D5, D6).

6) Refit the cover (18).

7) Fit the clamp ring (7) into position and tighten the clamp ring handle(s) (8), ensuring that the clamp ring is correctly located.

8) Connect the inlet and outlet connections.

9) Before start-up, the pump should be flooded with liquid at the seal faces as dry running will cause overheating and may damage the mating surfaces.

Replacing the Seal - type 2 or RB2.

ATTENTION Mechanical seals are precision products. Installation should be carried out to the laid down procedure. Seals should be installed in a clean environment with particular care given to the lapped and polished seal faces.

Notes: - For information on the seal fitted in your pump, please refer to the data sheet.
- The diagrams show seals with 'N' type seats, although different seats are available.

Tools required: Diluted soft soap solution, Seal fitting tube & sleeve (recommended).

Removing the old seal:

Dismantle the pump and seal as described on page S1.

Fitting the new seal:

- 1) For the 'Type 2' seal, remove the spring retaining cup if fitted and discard.
- 2) Ensure all components are clean. Any sharp edges on the shaft shoulder or keyway should be removed.
- 3) Fit the seat (2) into the seat ring (3) to form the seat assembly.
- 4) Press the seat assembly* fully down into the recess in the housing plate (1). Ensure that it is at right angles to the axis of the shaft and that the lapped sealing surface will face **towards** the mechanical seal assembly.
- 5) Fit the housing plate (1) into the flanged adaptor and tighten the housing plate screws (where applicable). Take care during assembly that the seal seat does not contact the shaft and become chipped. Ensure that the shaft guard (where supplied) is in position.
- 6) Ensure that the rubber bellows (4) are not cut or damaged during assembly.
- 7) Lubricate the inside sleeve of the bellows with a very slight smear of diluted soft soap solution. **Never use mineral oil, grease, vaseline, etc, as it is not hygienic and may degrade the rubber.**
- 8) Ensure that the seal face (5) is inserted with the raised face outwards, ie the lapped surface will face **towards** the seat (2).
- 9) Slide the seal unit onto the shaft until it makes contact with the seat (2), making sure that the bellows (4) is fully compressed. A fitting tube (6) is recommended for this operation.
- 10) The driving dogs (7) of the drive ring are to be correctly engaged in the slots of the drive sleeve.
- 11) Reassemble the pump as described on page S1.
- 12) Before start-up, the pump should be flooded with liquid at the seal faces as dry running will cause overheating and may damage the mating surfaces.

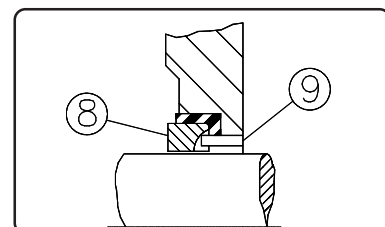
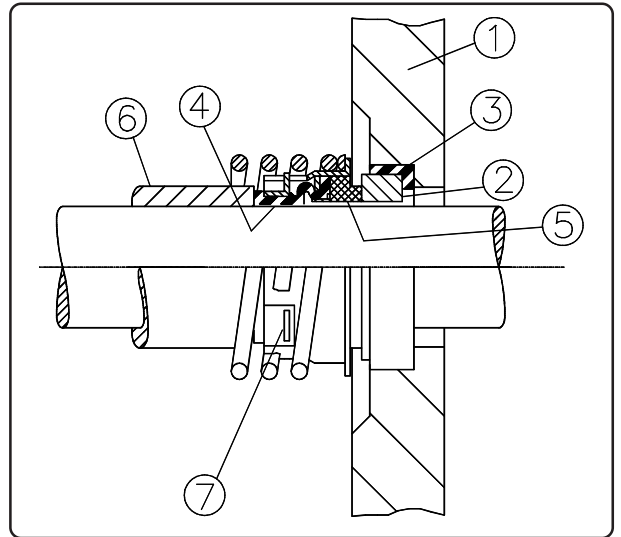

*Pegged seats:

When pegged seats are fitted, ensure that the hole or notch in the seat (8) is lined up with the peg (9) which protrudes from the seal seat housing. Failure to do so will result in seal failure.